

THIS DRAWING IS THE EXCLUSIVE PROPERTY OF PARLEG, INC. AND IS SUBJECT TO BEING RETURNED UPON REQUEST. IT SHALL NOT BE REPRODUCED IN WHOLE OR PART WITHOUT THE WRITTEN PERMISSION OF PARLEG, INC. ANY UNAUTHORIZED REPRODUCTION MUST BEAR THE PENALTY OF LAW.

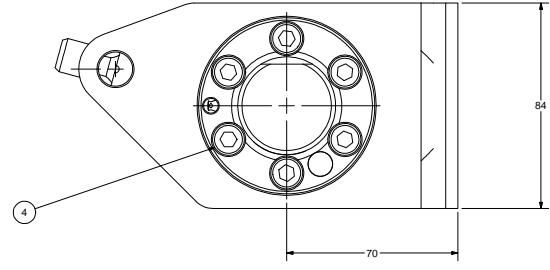

Parts List			
ITEM	QTY	PART NUMBER	DESCRIPTION
1	1	C4-RCI-MZ620-140018M	C4 Internal R/H Reverse Tool Holder
2	1	217-14952-001	MP620 Static Shank
4	6	SHCSM8X16	CAP SCREW M8 X 16 LG
5	3	SSM6X6	SET SCREW M6 x 6
6	1	SSPLG0125BSPT	1/8" BSPT PIPE PLUG
8	1	202-652-4470	O-RING 54.5 x 3
9	1	LB-SANDVIK	SANDVIK LABEL
10	1	C4-CU-CS-11	CAPTO C4 CLAMPING UNIT, STATIC
11	1	196.13636.004	LOCATION PIN
12	1	DWLM10X24	DOWEL PIN, M10 X 24LG

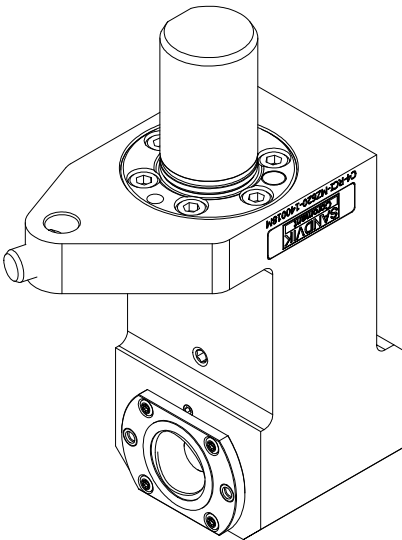
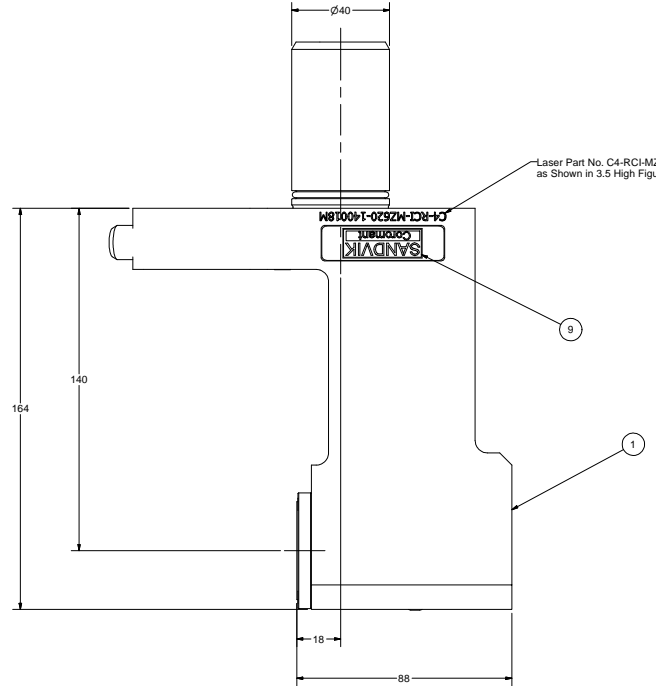
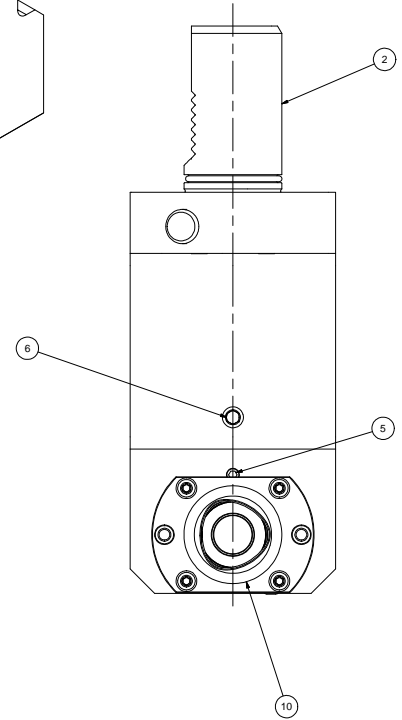

Laser Part No. C4-RCI-MZ620-140018M as Shown in 3.5 High Figures

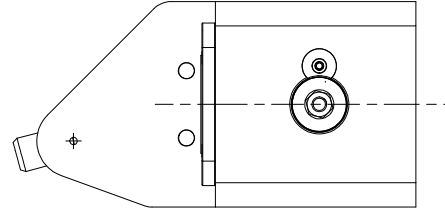
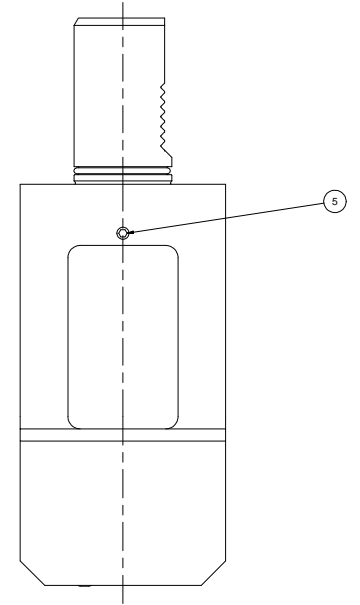

		<b>C4 Internal R/H Reverse Tool Holder</b>	
SPECIAL INSPECTION SWAMP CONCRETE ANCHORAGE & FOUNDATIONS	WORLD HEADQUARTERS 101 PERSIMMON PARKWAY HANFORD, NEW YORK 14456	DATE: 2/20/2006 SCALE: NONE	DRAWN BY: mbarcoi CHECKED BY:
PART NUMBER: <b>C4-RCI-MZ620-140018M</b>		REV: 1	