

ITEMS SHOWN ON THIS DOCUMENT CONTAIN PROPRIETARY INFORMATION OF PARLEC INC. AND IS SUBJECT TO BEING RETURNED UPON REQUEST. IT SHALL NOT BE REPRODUCED IN WHOLE OR PART WITHOUT WRITTEN PERMISSION OF PARLEC INC. ANY AUTHORIZED REPRODUCTION MUST BEAR THIS ENTIRE LEGEND.

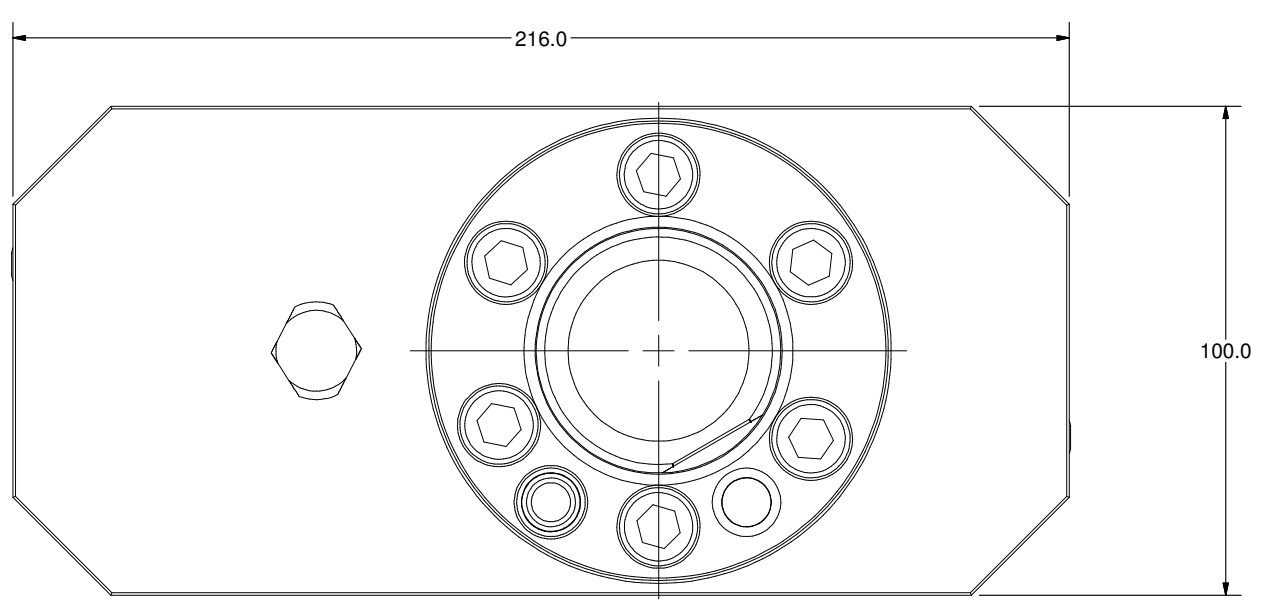

Laser Part No. C5-RCE-SQT30-000130MDT
As Shown in 3.5 High Figures.

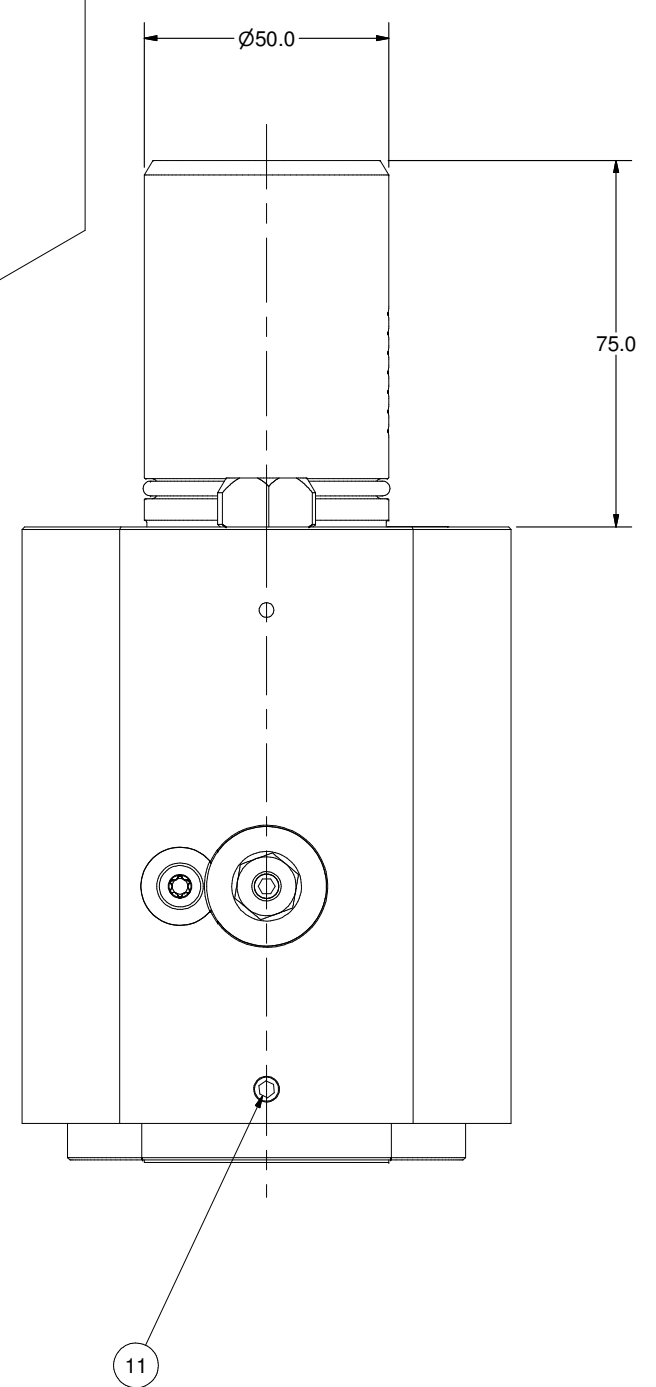
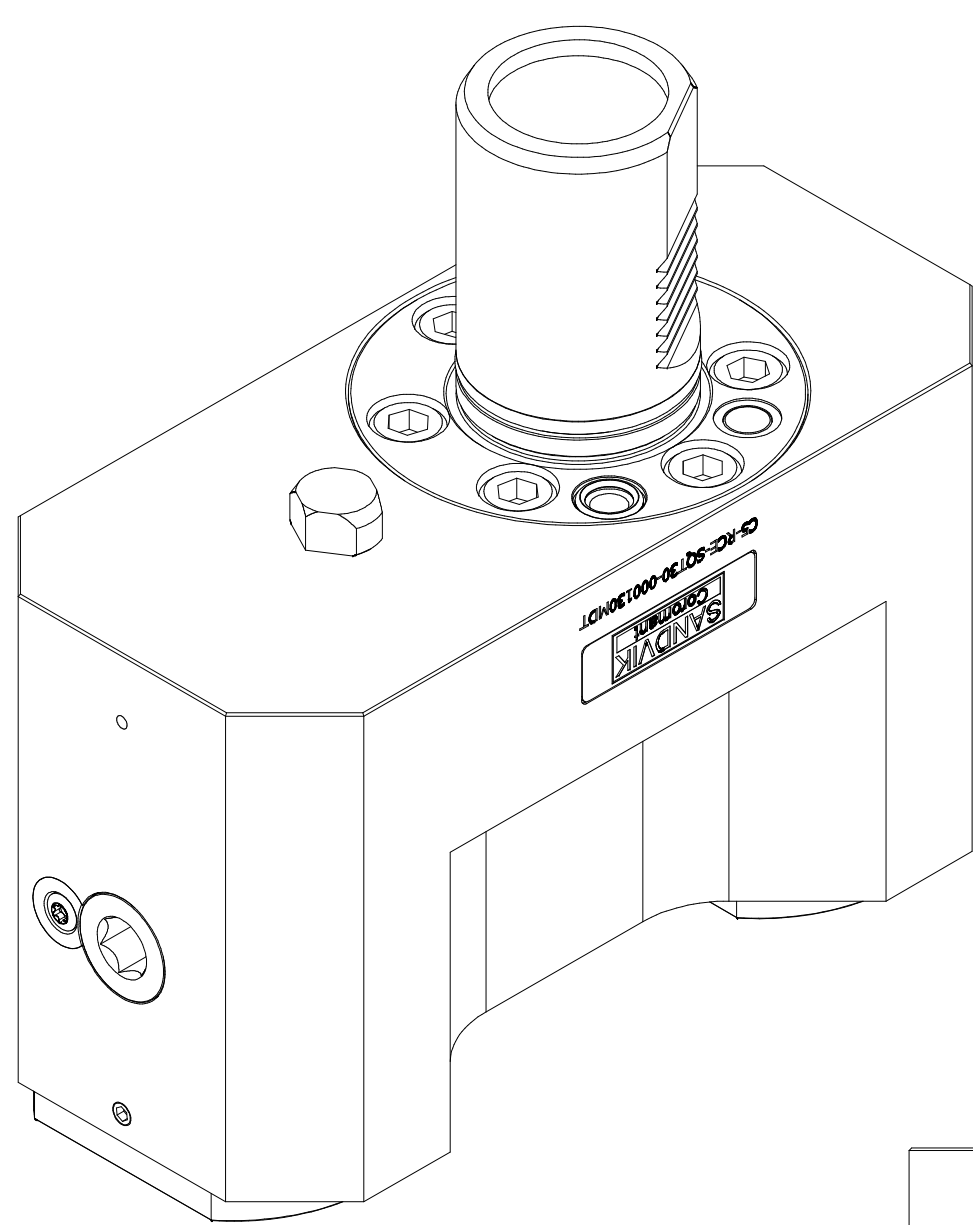
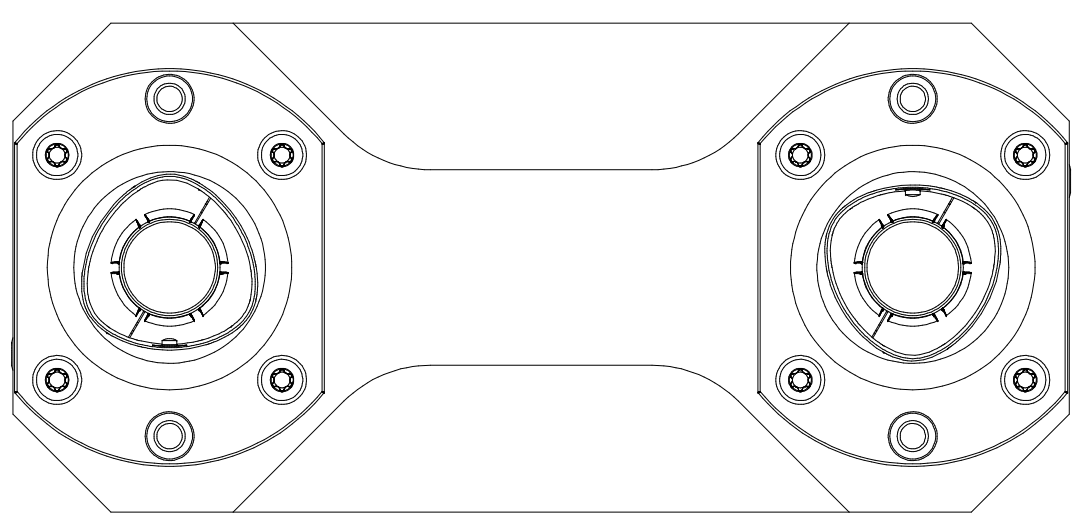
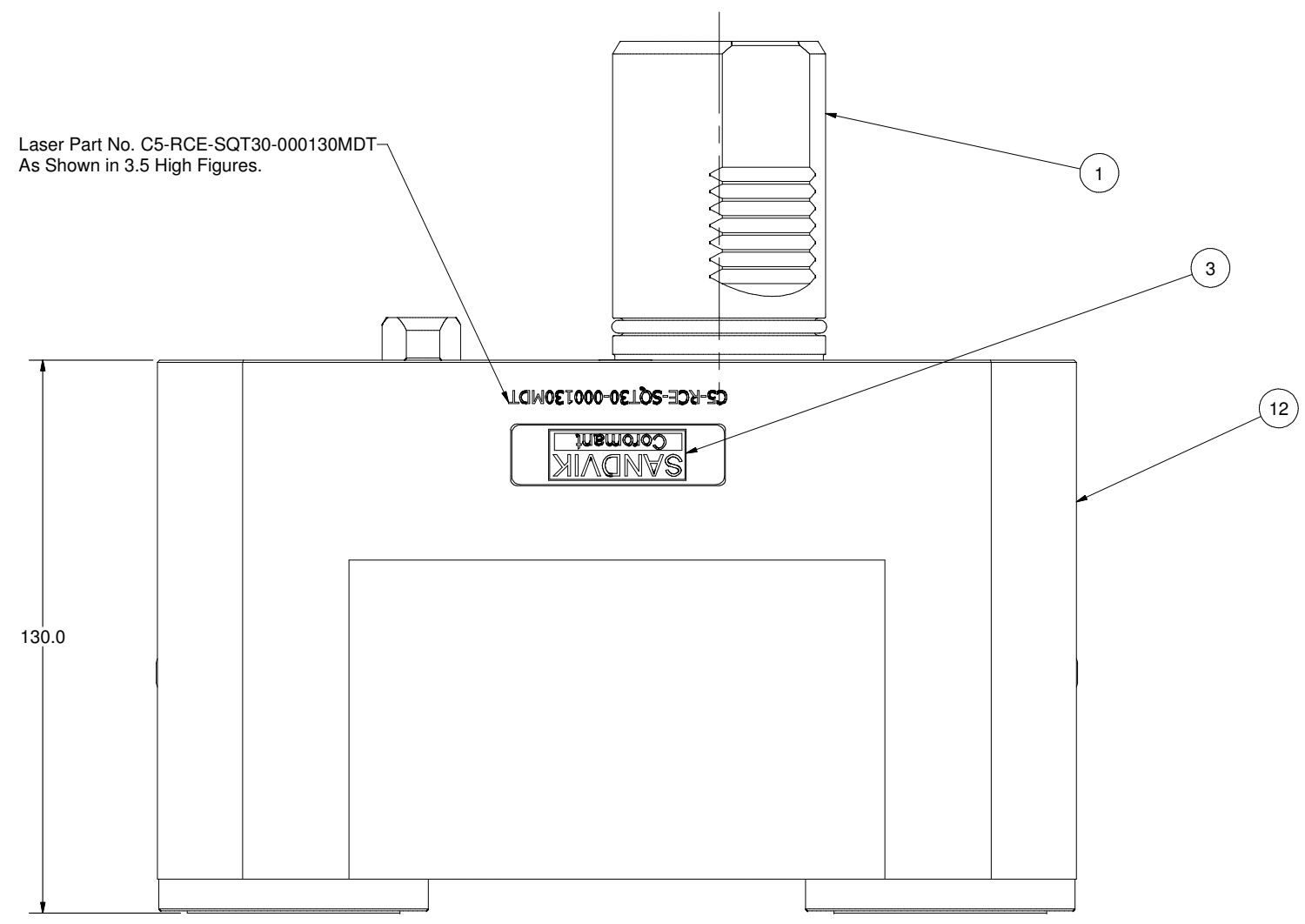

Parts List			
ITEM	QTY	PART NUMBER	DESCRIPTION
1	1	226-14129-002	SQT28 Static Shank
3	1	LB-SANDVIK	SANDVIK LABEL
4	6	SHCSM10X25	CAP SCREW, M10 x 25
11	1	SSM6X6	SET SCREW, M6 x 6
12	1	C5-RCE-SQT30-000130MDT-1	C5 Double Ext. Reverse Tool Holder
13	1	196.13636.004	LOCATION PIN
14	1	DWLM10X30	DOWEL PIN,
15	1	204-010-4470	O-RING 10 x 2
16	1	202-788-4470	O-RING 44.5 x 3
11	2	C5-CU-CS-11	CAPTO C5 CLAMPING UNIT, STATIC

				PART NAME: C5 Double Ext. LH Forward/Reverse Tool Holder	
THIRD ANGLE PROJECTION BREAK ALL UNNECESSARY SHARP CORNERS		(800) TOOL USA WORLD HEADQUARTERS 101 PERINTON PARKWAY FAIRPORT, NEW YORK 14450		SCALE: NONE DATE: 1/24/2006	
ANGLUAR: 3 T (DEGREE)		FINISH:		CHECKED BY:	
INCH DIMENSIONS: X ± .04, XX ± .015, XXX ± .005, XXXX ± .0002		METRIC DIMENSIONS: X ± .1, XX ± .05, XX ± .013, XXX ± .005		DRAWN BY: marcol	
PART NUMBER: C5-RCE-SQT30-000130MDT				REV. PR1	