

ITEMS SHOWN ON THIS DOCUMENT CONTAIN PROPRIETARY INFORMATION OF PARLEC INC. AND IS SUBJECT TO BEING RETURNED UPON REQUEST. IT SHALL NOT BE REPRODUCED IN WHOLE OR PART WITHOUT WRITTEN PERMISSION OF PARLEC INC. ANY AUTHORIZED REPRODUCTION MUST BEAR THIS ENTIRE LEGEND.

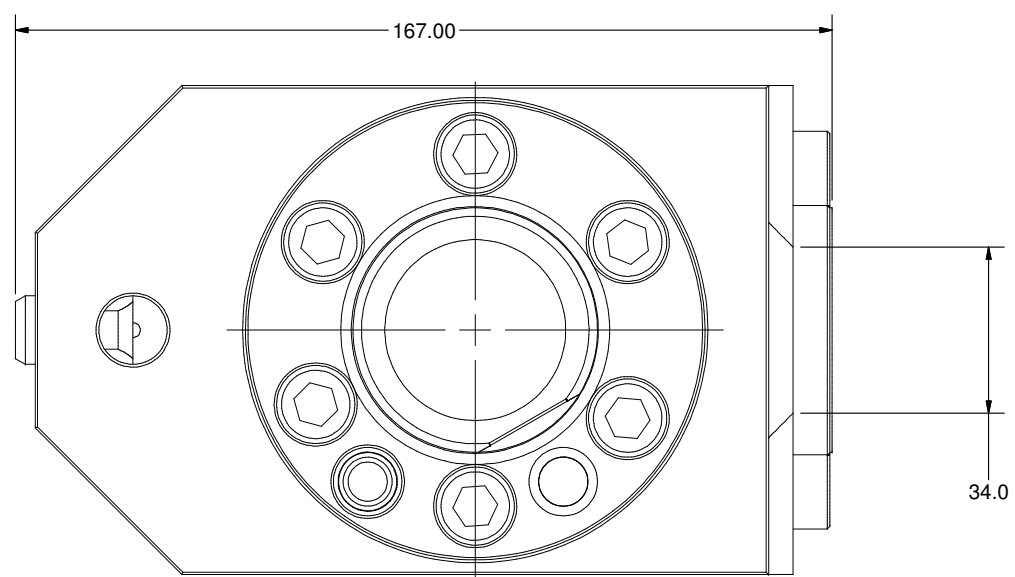

Parts List			
ITEM	QTY	PART NUMBER	DESCRIPTION
1	1	226-14129-002	SQT28 Static Shank
3	1	LB-SANDVIK	SANDVIK LABEL
4	6	SHCSM10X25	CAP SCREW, M10 x 25
9	1	SSPLG0125BSPT	1/8" BSPT PIPE PLUG
10	1	SSM6X6	SET SCREW, M6 x 6
11	1	C5-RCI-SQT30-175073 M-1	C5 Int. Forward Tool Holder
7	1	C5-CU-CS-11	CAPTO C5 CLAMPING UNIT, STATIC
8	1	196.13636.004	LOCATION PIN
9	1	DWLM10X30	DOWEL PIN,
10	1	204-010-4470	O-RING 10 x 2
11	1	202-788-4470	O-RING 44.5 x 3

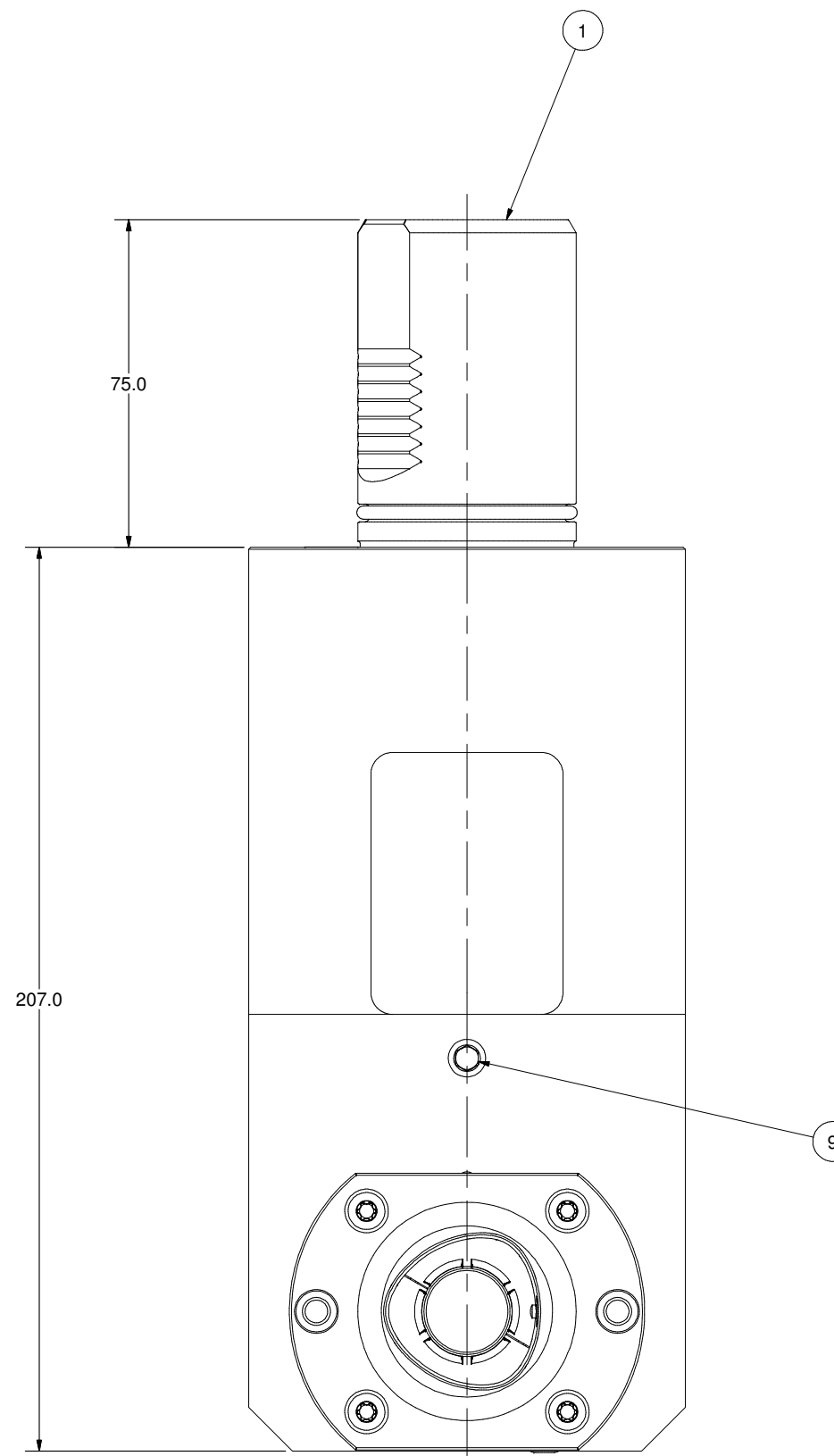
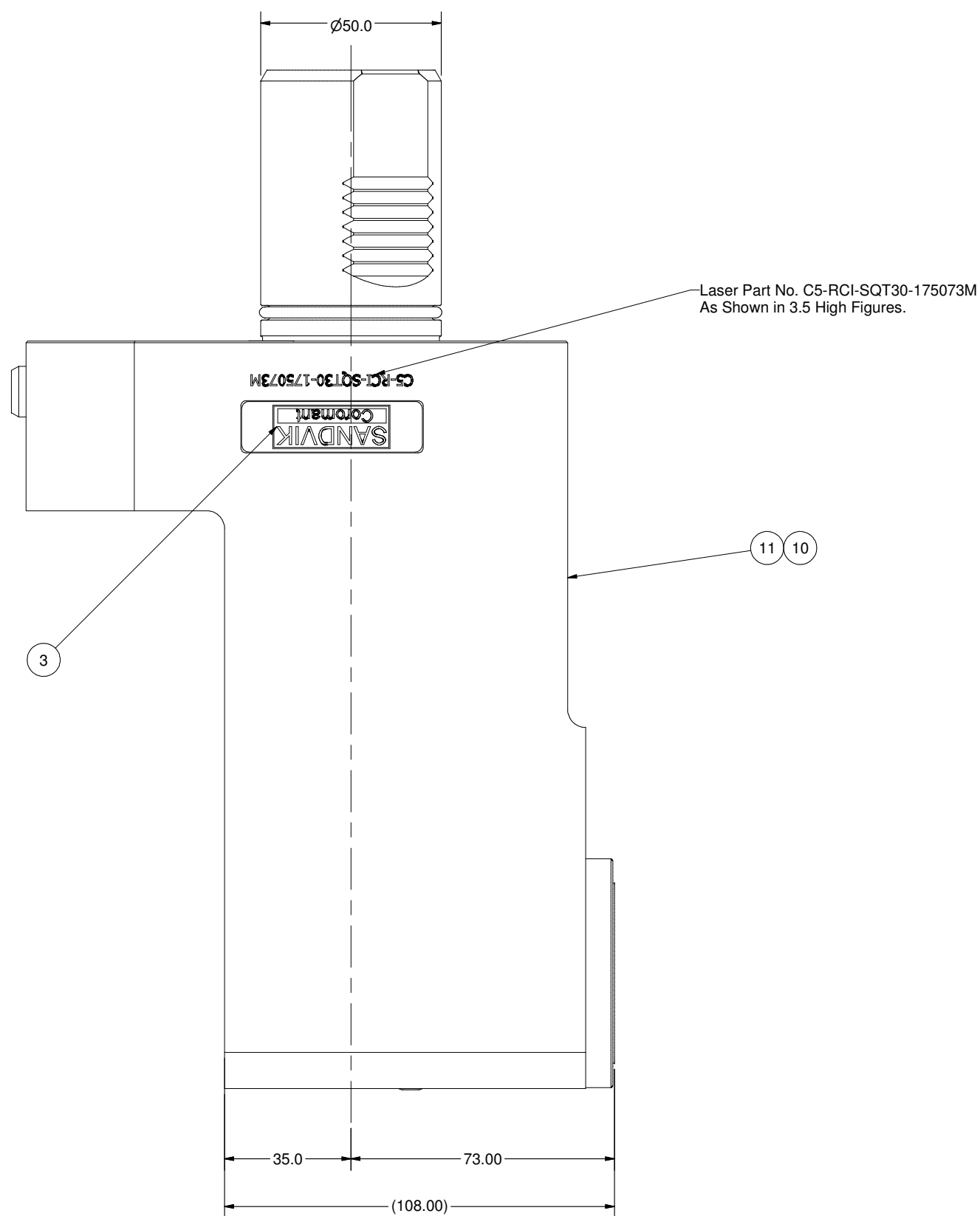
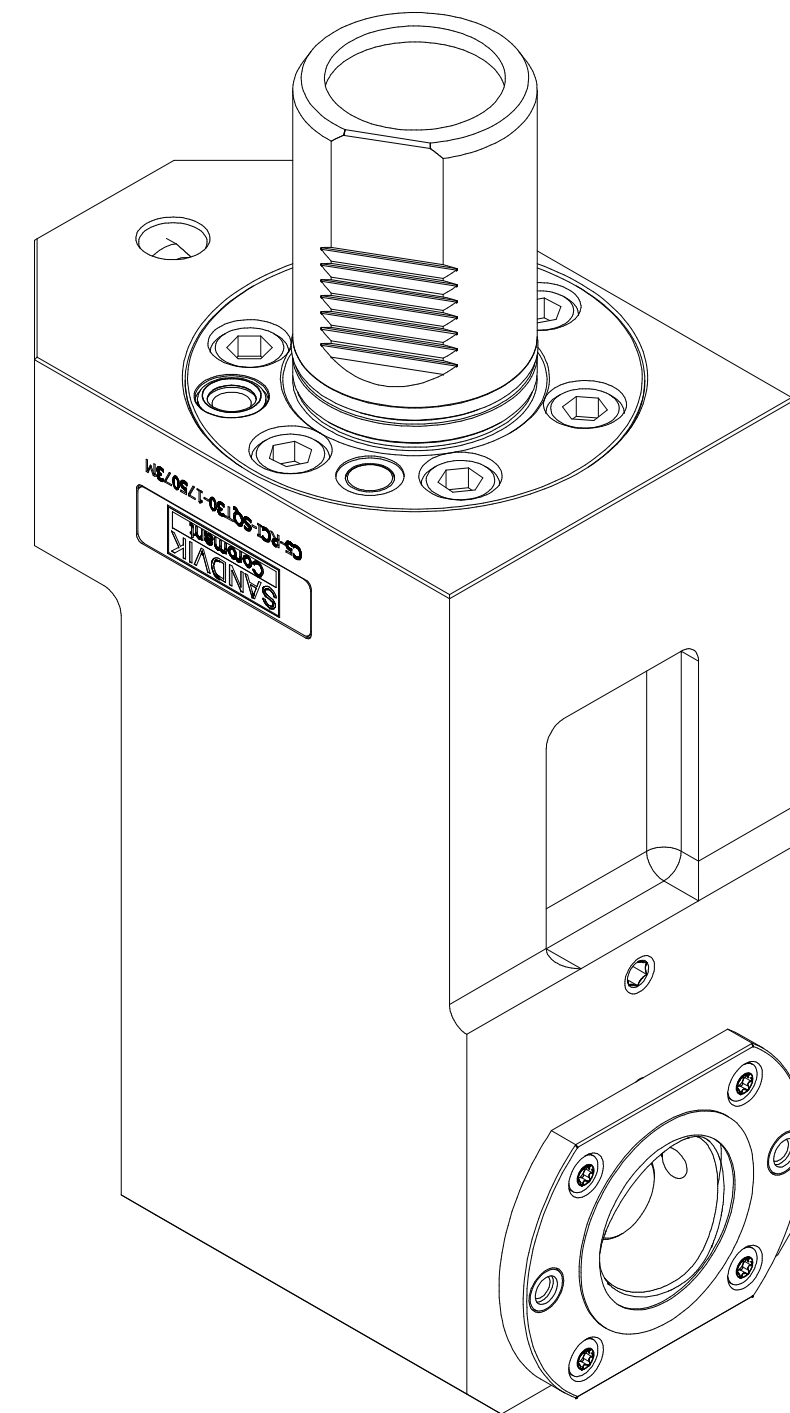

THIRD ANGLE PROJECTION BREAK ALL UNNECESSARY SHARP CORNERS ANGULAR ± 1° (DEGREE)	PARLEC (800) TOOL USA WORLD HEADQUARTERS 101 PERINTON PARKWAY FAIRPORT, NEW YORK 14450	PART NAME: C5 Internal L/H Forward Tool Holder MATERIAL: - H. T.: - FINISH: - DRAWN BY: marcol CHECKED BY: -	SCALE: NONE DATE: 1/24/2006
INCH DIMENSIONS: X ± .04, XX ± .015, XXX ± .005, XXXX ± .0002	METRIC DIMENSIONS: X ± 1, XX ± 0.05, XX ± 0.13, XXX ± 0.005	PART NUMBER: C5-RCI-SQT30-175073M	REV. PR1