

CAT and BT Taper Specifications

CONNECTION IS EVERYTHING

No matter what the spindle application, Parlec offers simple, highly repeatable and versatile tooling solution.

CAT V Flange Taper Specifications

- Meets or exceeds ASME B5.50-2009 specifications and all current specification updates except where improvements are made for high speed operation.
- All Parlec CAT tooling incorporates ParSymmetry for balance and chip hole for identification.

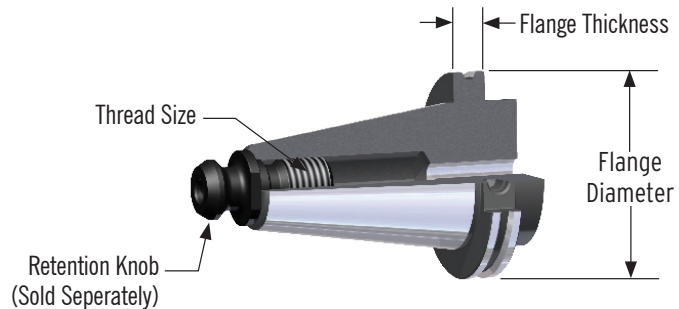

CAT TAPER SPECIFICATIONS

Taper Type	Gage Diameter	Flange Diameter	Flange Thickness	Thread Size
C40	1.750	2.50	.625	5/8" - 11"
C50	2.750	3.87	.625	1" - 8"
C60	4.250	5.50	.625	1 1/4" - 7"
C40F	1.750	2.50	.711	5/8" - 11"
C50F	2.750	3.87	.691	1" - 8"

BT Taper Specifications

- Meets or exceeds JIS B6339-1986 specifications.
- Taper is toleranced so that any error increases rate of taper only. Refer to Manufacturing Specifications for tolerance specifications.

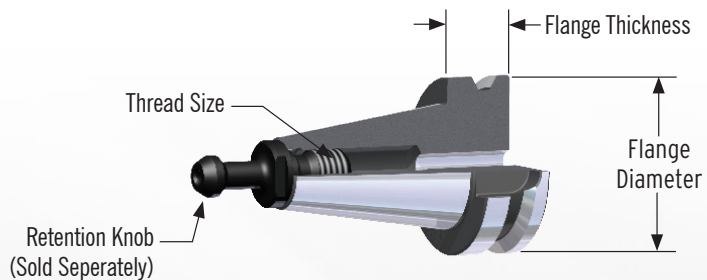

BT TAPER SPECIFICATIONS

Taper Type	Gage Diameter	Flange Diameter	Flange Thickness	Thread Size
B30	1.25	1.81	0.787	M12 - 1.75
B40	1.75	2.48	0.984	M16 - 2.0
B50	2.75	3.94	1.378	M24 - 3.0
B30F	1.25	1.81	0.865	M12 - 1.75
B40F	1.75	2.48	1.062	M16 - 2.0